



tekno system[®]

Italian design for CCTV since 1979



The Market

Extremely successful in the Italian CCTV market from the beginning, we have started to establish ourselves worldwide more than 20 years ago. Tekno Systems already has an established client base in the United States, Europe, the UK, M.E. and South Africa.



Tekno System was established in Italy in 1979 and has since then provided professional and innovative solutions for the international CCTV market. Amongst the first in Europe to design such products, Tekno System is one of the pioneers of the CCTV industry. Coupled with excellent Italian design flair, its name has become a benchmark for quality, innovative design and reliability. Located in the heart of Northern Italy in the town of Carrè (Vicenza) is Tekno System's headquarters. This comprises a modern research & development section, product testing department, as well as a final production plant. It is here that the ideas of our designers are turned to reality. Stringent quality controls, materials and product testing, as well as a proven production environment all ensure the excellent quality of our delivered end product. An efficient customer service department is at hand to provide pre and post sales support for customers in Italy and Worldwide.





Products

Tekno System specialises in high quality accessories for CCTV systems. These include camera housings, camera brackets, infra-red illuminators, monitor hangers, PTZ drivers, video equipment and joystick controllers.

The main advantage Tekno has over other manufacturers, is the high level of design. Products are designed not only with quality in-mind, but to be functional, easy-to-install, as well as being mechanically accurate. End-users are impressed with the outward-design look of our products and installers happy to use our products because of their easy integration.

For over 30 years, Tekno has worked closely with many of the largest international CCTV distributors. This has helped us to keep on top of worldwide trends in CCTV design and product demand. It has also helped us to stay competitive and allowed us to offer a quality range of products with good pricing.

Another one of our strengths is our ability to offer customised products and solutions, quickly and efficiently. With our excellent technical and design capability, we are continuously working on new product designs and updates to keep our customers ahead in the ever expanding CCTV market.

Contents

4	Emotion
6	Emotion Two Eyes
8	Emotion BOTRO
9	Housing CHXES
10	Housing KITXESP
11	Camera housings LINEA X
12	Explosionproof housings CHEP
14	Keyboard TSK1
14	Monitors brackets
16	Hyperion
18	Hyperion One
21	Hyperion WL
22	Hyperion One PoE
22	Hyperion hybrid
23	Nano
24	Camera housings LINEA 1
25	Camera housings LINEA 2
26	Camera housings LINEA 3
27	Camera housings LINEA 6
28	Camera housings LINEA R
29	Camera housings LINEA 11
30	Camera housings HiPoE
32	Thermal camera housings
32	High performance housings
33	Pressurized camera housing
33	Signal plates
34	Accessories for camera housings
34	Camera brackets
35	Adapters
35	Brackets for camera housings

emotion

Camera module
Thermal
Lens

Description

The Emotion is the new product range of particularly rugged PTZ devices, dedicated to video surveillance for indoor and outdoor applications especially where the Stainless Steel Aisi316L is required to face corrosion and harsh weather conditions. The unit is easy to install, versatile and gives wide possibility of customization. Emotion may host cameras with motorized zoom lenses, block module cameras with serial control, thermal cameras. Horizontal (PAN) as well as vertical (TILT) axes allow continuous rotation. The positioning is extremely fast thanks to the moving speed that may reach 200°/s for both axes. The system works with mechanical solutions that do not require maintenance.

Configuration

The system configuration is easy through a menu (OSM). Up to six languages can be chosen or modified and customized. The device can be addressed up to 4095 units. The Emotion configuration is completely done by remote, there is no need of opening it. Firmware upgrades and languages customization are done by remote as well.

Mechanical features:

- Entirely made from stainless steel Aisi316L
- Top mount
- Transmission through toothed belt
- Slip-ring
- Zero backlash
- Continuous vertical and horizontal rotation
- Speed pan and tilt 0.01° up to 200°/s
- Simplified installation
- Nr. 4 cable glands M16 for connections



Stainless Steel positioning device

ELECTRICAL FEATURES:

Feeding voltage

24Vac 50/60Hz 120W
110Vac 50/60Hz 120W
230Vac 50/60Hz 120W

Serial

Nr. 2 RS485 configurable multiprotocol

Camera

12Vdc – 800mA
Separate wire Lens Control

Video signal:

Up to 2 video lines (1V, 75Ohm) PAL/NTSC

Interface

Nr. 4 alarm input (10-35V)
Nr. 4 output open collector type

Environment

Developed for indoor/outdoor applications
Working temperature range: -40°C/+50°C

Standards applied

CEI EN60950-1, EN61000-6-3 and
EN50130-4
FCC part 15, class B
IP66 EN60529

ACCESSORIES

Wiper
Water tank with pump
Stainless Steel Wall Bracket
Stainless Steel Corner Mount
Top Pole Mount Adapter



emotion *TWO EYES*

Description

The Emotion Two Eyes is the latest version of particularly rugged PTZ device, dedicated to visible and thermal applications for videosurveillance especially where the Stainless Steel Aisi316L is required to face corrosion and harsh weather conditions. Emotion Two Eyes hosts a block module camera with serial control and a thermal camera. Horizontal (PAN) as well as vertical (TILT) axes allow continuous rotation. The positioning is extremely fast thanks to the moving speed that may reach 150°/s for both axes. The system boasts an innovative infrared LED double array.

Configuration

The system configuration is easy through a menu (OSM). Up to six languages can be chosen or modified and customized. The device can be addressed up to 4095 units. The Emotion configuration is completely done by remote, there is no need of opening it. Firmware upgrades and languages customization are done by remote as well.

Mechanical features:

Entirely made from stainless steel Aisi316L
Top mount
Transmission through toothed belt
Slip-ring
Zero backlash
Continuous vertical and horizontal rotation
Speed pan and tilt 0.01° up to 200°/s
Simplified installation
Nr. 4 cable glands M16 for connections



Stainless Steel positioning device



ELECTRICAL FEATURES:

Feeding voltage

24Vac 50/60Hz 120W
110Vac 50/60Hz 120W
230Vac 50/60Hz 120W

Serial

Nr. 2 RS485 configurable multiprotocol

Camera

Sony 36X Zoom Camera Module

Thermal Camera

Preinstalled Uncooled Module 640x480 or 320x240.

Thermal Optic

Fixed

Video signal:

Up to 2 video lines (1V, 75Ohm) PAL/NTSC

Interface

Nr. 4 alarm input (10-35V)
Nr. 4 output open collector type

Infrared LED

850nm wavelength
Double LED array

Environment

Developed for indoor/outdoor applications
Working temperature range: -40°C/+50°C

Standards applied

CEI EN60950-1, EN61000-6-3 and
EN50130-4
FCC part 15, class B
IP66 EN60529

Accessories

Wiper
Water tank with pump
Stainless Steel Wall Bracket
Stainless Steel Corner Mount
Top Pole Mount Adapter

emotion **BOTRO**

Big Optics Thermal Rotating Object

Description

Botro meets full compliance with integrated Thermal Modules and big lenses. As an integrator partner, Tekno System has successfully developed and incorporated the telemetry control of big thermal zooms into an extra large housing for the Emotion AISI316L Stainless Steel Pan & Tilt unit. The system boasts a continuous rotation of 360 degrees on both axes at high speed and with maximum precision.

Mechanical features:

Entirely made from stainless steel Aisi316L
Top mount
Transmission through toothed belt
Slip-ring
Zero backlash
Continuous vertical and horizontal rotation
Speed pan and tilt 0.01° up to 150°/s
Simplified installation
Nr. 4 cable glands M16 for connections

Electrical features:

Serial

nr. 2 RS485 configurable multiprotocol

Camera

Sony 36X Zoom Camera Module

Thermal Camera

Preinstalled Uncooled Module 640x480 17µ or 25µ pitch.

Thermal Zoom

Motorized 15-100mm.

Video signal:

2 video lines (1V, 75Ohm) PAL/NTSC

Environment

Developed for indoor/outdoor applications
Working temperature range: -40°C/+50°C

Standards applied

CEI EN60950-1, EN61000-6-3 and
EN50130-4
FCC part 15, class B
IP66 EN60529

Accessories

Stainless Steel Wall Bracket
Stainless Steel Corner Mount
Top Pole Mount Adapter

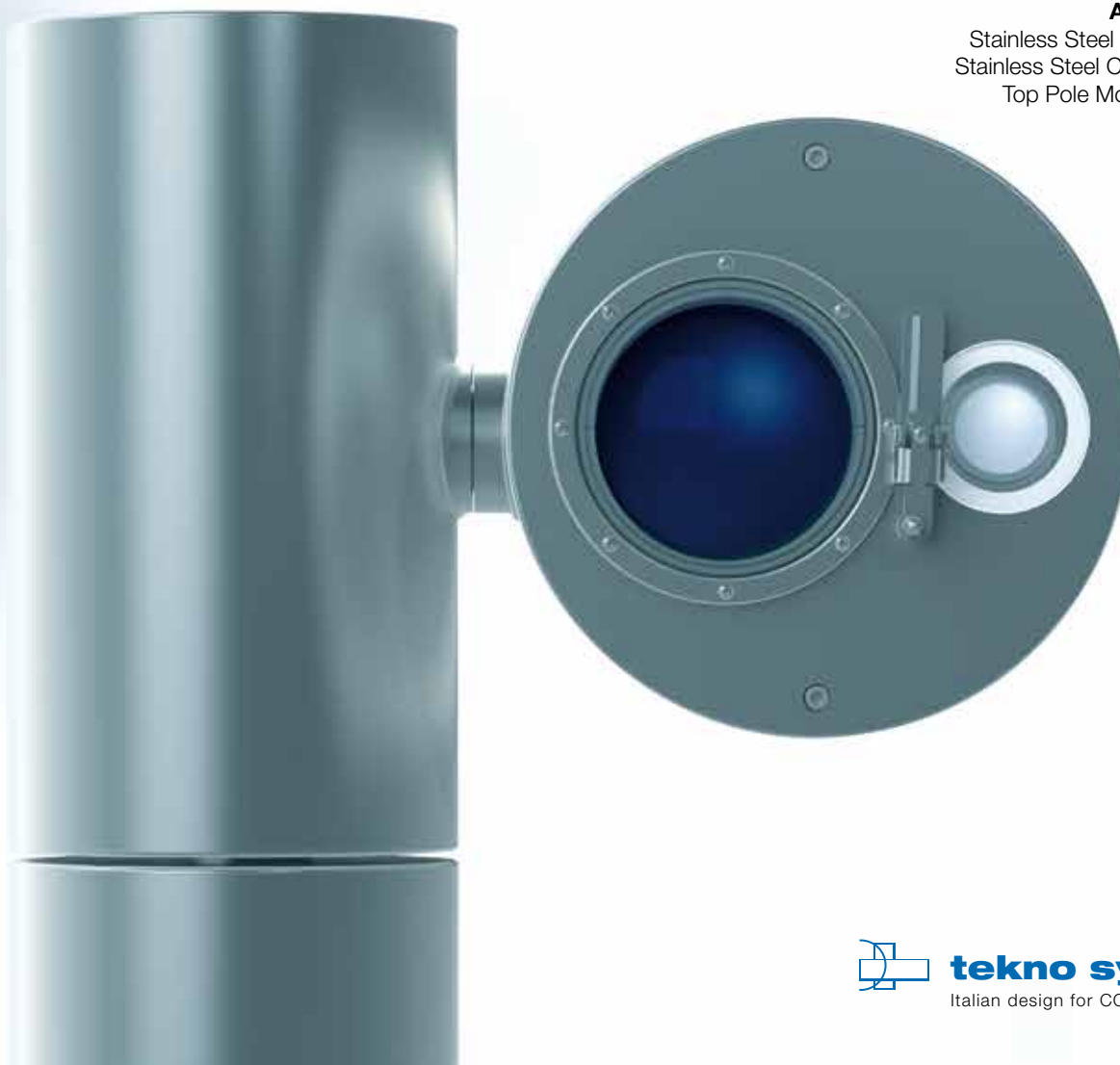

Housings **CHXES**

New concept Stainless Steel Camera housing

Construction

AISI 316L Stainless Steel

Internal dimensions

BxH 85 x 92 mm (standard) / BxH 85 x 85 mm (with wiper)

Usable length

Standard 281 mm / HiPoE MKII 257mm

Usable window

Tempered glass; Ø 69 mm

Germanium window; Ø 54 mm or Ø 74 mm

Weatherproof rating

IP66

Cable glands

N. 3 M16x1,5 / Sealed RJ45 Connector

Versions

Standard / with wiper

(Temp.Range: -40°C/+60°C)

HiPoE MKII / HiPoE MKII Plus

(Temp.Range:-20°C/+50°C)

HiPoE MKII / HiPoE MKII Plus with wiper

(Temp.Range:-20°C/+50°C)

Thermal with Germanium window

ACCESSORIES

Heater with thermostat 12-24Vac/Vdc or 100-240Vac

Wide Range Power Supply Unit :

Vin 88-264V Vout 12Vdc 2,1A

Defogging system

Built-in wiper (with integrated telemetry receiver and pc software)

Germanium filter for thermal cameras

Water Tank with pump

(with or without telemetry receiver)

5 liters capacity, 5 meters prevalence

or 25 liters capacity, 18 meters prevalence

Brackets and Adapters

BWXHX – Wall Bracket and Swivel

CMX – Corner Adapter for BWX

PAX – Pole Adapter for BWX



Housings **KITXESP, KITXESPC**

Cable management Stainless Steel camera housing
available with wall bracket or in ceiling mount version



Construction
AISI 316L Stainless Steel

Internal dimensions
BxH 85 x 92 mm (standard)
BxH 85 x 85 mm (with wiper)

Usable length
Standard 281 mm / HiPoE MKII 257mm

Usable window
Tempered glass; Ø69mm
Germanium window; Ø54÷Ø74mm

Weatherproof rating
IP66

Cable Management
Vandalproof with cable protection through
an adjustable wall or ceiling bracket

Cable glands
N. 3 M16x1,5 / Sealed RJ45 Connector

Versions
Standard / with wiper
(Temp.Range: -40°C/+60°C)
HiPoE MKII / HiPoE MKII Plus
(Temp.Range:-20°C/+50°C)
HiPoE MKII / HiPoE MKII Plus with wiper
(Temp.Range:-20°C/+50°C)
Thermal with Germanium window

ACCESSORIES
Heater with thermostat 12-24Vac/Vdc or 100-240Vac
Wide Range Power Supply Unit : Vin 88-264V Vout 12Vdc 2,1A
Defogging system
Built-in wiper (with integrated telemetry receiver and pc software)
Germanium filter for thermal cameras

Water Tank with pump
(with or without telemetry receiver)
5 liters capacity, 5 meters prevalence
or 25 liters capacity, 18 meters prevalence

Adapters
CMX – Corner Adapter
PAX – Pole Adapter



Housings **LINEA X**

Stainless Steel camera housings for special applications, available in standard CHXS, vandal-proof CHX and liquid cooled CHXC versions

Construction

AISI 316L Stainless Steel

Internal dimensions

WxH 85 x 85 mm

Usable length

342 mm

Weatherproof rating

IP68 at 50 m (CHX)

IP68 at 100 m (CHXS)

IP68 at 10 m (CHXC)

Cable glands

No. 2 M16x1,5

ACCESSORIES

12-24 Vac/Vdc or 100-240 Vac heater with thermostat (for CHX and CHXS)

400mA power supply unit, 230Vac/12Vdc or 230Vac/24Vac

SSX - Stainless Steel Sunshield

VG - Germanium filter for thermal cameras

ACCESSORIES (for CHXC only)

BAX - Air barrier for window cleaning

GFA - Compressed-air filtering unit

FH - Infrared Filters Holders (up to 3 filters)

IR - Infrared Reflection Filter (Max one per camera housing; to be installed faced to the window)

FA - Infrared Absorption Filter (Max two per camera housing; to be installed faced to the window)

VV - Vycor® glass for high temperatures (only with BAX)

Brackets and Adapters

BWXHX – Wall Bracket and swivel

CMX – Corner Adapter for BWX

PAX – Pole Adapter for BWX

CBX – Ceiling Adapter for BWX



CHX



CHXC



BAX

GFA

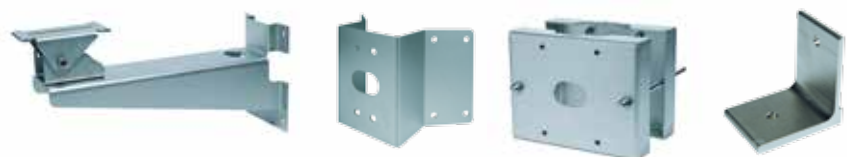

BWXXH

CMX

PAX

CBX

Explosionproof housings **CHEP**



ATEX and
IECEx certified



The explosion proof equipment has been designed to be installed in potentially explosive atmospheres, where flammable gasses and powders are present.

The CHEP housing has been certified to meet ATEX and IECEx standards and can be installed in hazardous areas, indoor or outdoor, 1-21 and 2-22 classified. Constructed of a particular anticorrosive aluminium alloy, this equipment is available in two different lengths, 380 and 430 mm.

The anodic oxidation treatment assures an extremely high resistance against corrosive atmosphere agents, salty fog and air pollutants.

On the back side, two cable glands (1/2" or 3/4") allow to connect the devices inside the housing in high or low voltage. On request, different brands and types can be provided.

A special version in AISI 316 Stainless steel or in Bronze B14 has been certified for mine applications.

This explosion proof enclosure can host analog, digital and thermal cameras. In this last case, the housing is equipped with a Germanium filter and a protective grid.

It is also available with HiPoE technology.

CHEP housing is ATEX/IECEx certified even for laser devices radiation class 1 and 2 that find many applications for civil as well as industrial use. In particular they are utilized to monitor industrial processes, to measure levels and distances, to control moving things, to check objects' position (i.e. vessels, cars, etc).



Construction

Anticorrosive Aluminium

External dimensions

Ø 190 X 380 mm or Ø 190 X 430 mm
External dimensions with sunshield
Ø 208 X 450 mm or Ø 208 X 500 mm

IP protection degree

IP66 and IP67
ATEX and IECEx certified

ATEX Execution

II 2GD Ex d IIC/IIB T6 Ex tD A21 IP66/67 T85°C
I M2 Ex d I

IECEx Execution

Ex d IIB/IIC T6
Ex tD A21 IP 66/67 T85° C
Ex d I

Marking

Laser incision

Heater

Heater with thermostat for
temperatures among
- 20°C and + 50°C
(12-24Vac/Vdc o 100-240Vac)

Triple heater with thermostat
for temperatures among
- 50°C and + 50°C
(12-24Vac/Vdc o 100-240Vac)

Power supply

400mA, 230V~/12VDC,
230V~/24V~,
115V~/24V~,
24V~/12VDC

ACCESSORIES

Sunshield

Frontal glass protection grid
(for thermal version)

Bracket with swivel for wall
or ceiling mounting

Special versions

Housing with Germanium filter

Housing for mines

Housings HiPoE MKII, HiPoE MKII Plus



Multiprotocol Control Keyboard **TSK1**



TSK1

The TSK1 multi-functional control keyboard represents the reference within the video surveillance sector as for the control and management of systems. This keyboard controls the most popular matrices, multiplexers, DVR, speed domes, P&T units and cameras. The possibility to work with different protocols and the extreme ease of use and set-up make the TSK1 control keyboard a versatile instrument to be used with the most complex CCTV systems. Each of its three independent serial ports can be easily associated to one of the different protocols that can be selected from a list which is constantly updated. Features like the ergonomic and innovative design, the bright back-light LCD ensuring proper working conditions even in dark environments, as well as the attention we paid on details such as the soft-touch surface finishing, make this product unique in its kind.

The wide and bright LCD allows the operator to intuitively navigate throughout the various pages of the functional menu of the controlled devices that can be easily selected and configured. The proportional three-axis joystick allows to control with the maximum precision devices like Speed Domes and Pan&Tilt Units. The jog-shuttle allows a very easy control of Video Recording Devices.

It's also possible to activate an internal buzzer for specific alarm condition or devices communication errors.

The firmware upgrade to a new release can be done from a PC through the RS232 serial port.

The system access is protected by three password levels. An easy and intuitive software allows a quick setup of the keyboard.

Monitor brackets

LBWS



Compact wall mount bracket in carbon steel and thermoplastic resin, suitable for LCD monitors from 15" to 23", VESA 75/100

LBW



Wall mount bracket in carbon steel and thermoplastic resin, suitable for LCD monitors from 15" to 23", VESA 75/100

LBC



Ceiling mount bracket in carbon steel and thermoplastic resin, suitable for LCD monitors from 15" to 23", VESA 75/100

HYPERION



No IR illuminator



IR illuminator



HYPERION

Cable management and angle adjusting
Infrared LED Illuminator



Hyperion represents a time-proven reference within the professional IR illuminator sector. It has been developed to satisfy any CCTV requirement with differentiated and versatile versions.

In particular, the choice of materials, the cable management and the user friendly adjustment system, place it at the top of the range.

Installation is much simplified by the absence of any external power feeding unit.

It guarantees a high quality image with low consumption till the farthest distances.



Cable Management

Vandalproof with cable protection

3D Angle Adjusting System

Screw with locking system

Open: $\alpha/2 \leq 30^\circ$

Close: $\alpha/2 \leq 10^\circ$

Tilt: $-20^\circ/+50^\circ$

Pan variable

Ultimate LED technology

850nm new generation Infrared LED

940nm available on request

Surface mounting technology (SMT)

Long life

High efficiency and low consumption LED

LED MTBF: 50.000 hours

Main Power Supply Inside

Easy to install with direct power feeding from the mains

Heat dispersion body

Die cast Aluminium radiant body for optimal thermal yield

Options

Available in versions

with different LED angle beam:

15° / 30° / 60° / 120°

Available in versions

with different LED power

Up to 250m

Technology

Aluminium die cast molding

and Technopolymers

Weatherproof rating IP66 / IP67

Dry contact for Day/Night camera switch

Integrated photocell switch

Low Voltage

Whole range available

also in 24 VAC/DC



HYPERION ONE

Compact Infrared LED Illuminator
compatible with any camera housings.

Wall/Housing Mount Bracket

Compatible with any camera housings

Ultimate LED technology

850nm new generation Infrared LED
940nm available on request
Surface mounting technology (SMT)

Long life

High efficiency and low consumption LED
LED MTBF: 50.000 hours

Main Power Supply Inside

Easy to install 240 VAC main power supply

Heat dispersion body

Die cast Aluminium radiant body for optimal thermal yield

Options

Available in versions with different LED angle beam : 15° / 30° / 60° / 120°
Available in versions with different LED power
Up to 150m

Technology

Aluminium die cast molding
and Technopolymers
Weatherproof rating IP66 / IP67
Dry contact for Day/Night camera switch
Integrated photocell switch

Mechanical

N.2 Cable Glands M16x1.5 precabled (2m)

ACCESSORIES

BWHYP1 : Optional Wall Bracket
BWRHYP1 : Adapter for Linea R Camera Housing

Low Voltage

Whole range available
also in 12-24 VAC/DC



HYPERION / HYPERION ONE

Maximum distance beam charts

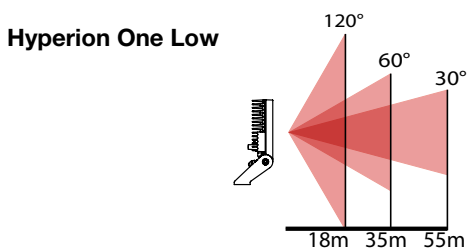
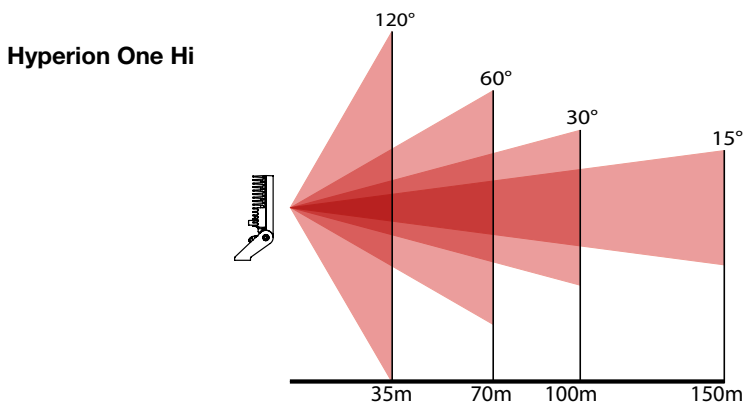
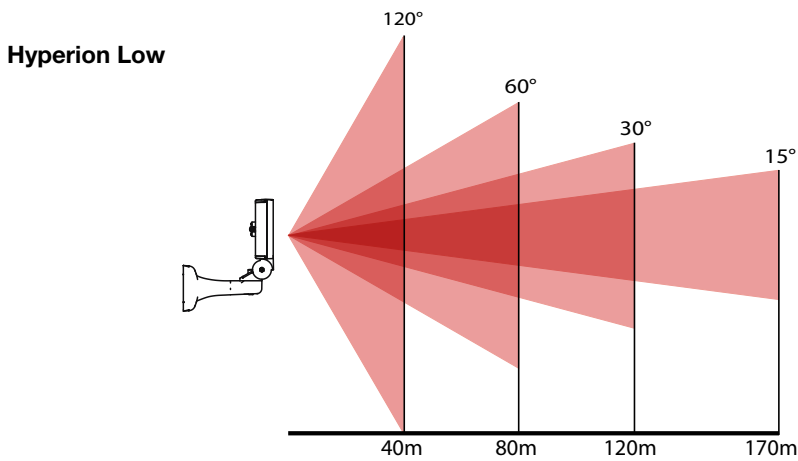
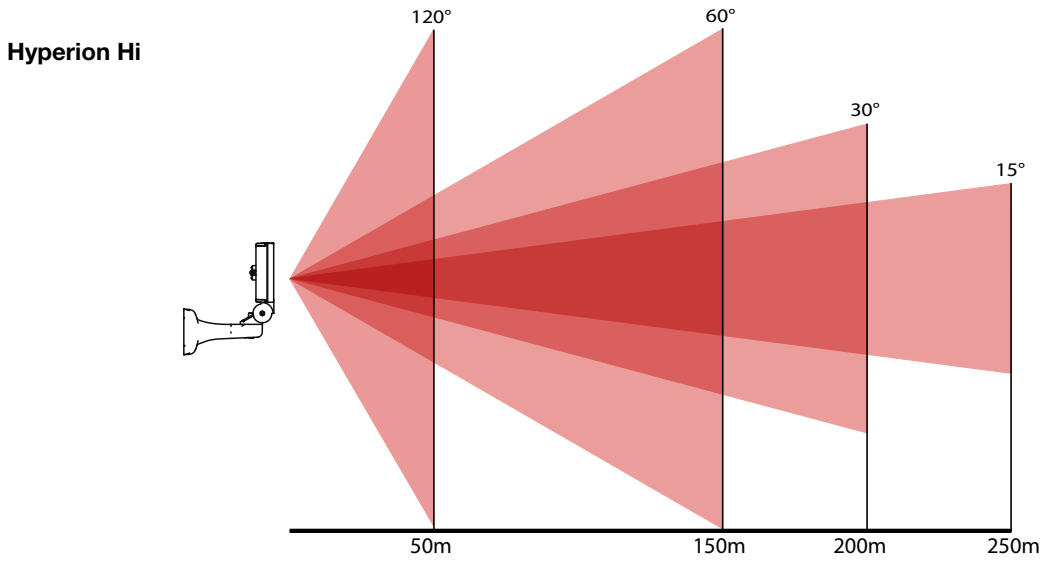

The maximum distance has been verified using a camera with a Sony Ex-View 1/3" CCD sensor and lens opening F: 1,3. The achievable distances can change according to the used camera sensor, lens luminosity and the reflection factor of the lightened area. The maximum distance is reduced by about 30% in case of Sony SuperHAD 1/3" sensor.

HYPERION WL

Cable management and angle adjusting White Light LED Illuminator



Cable Management

Vandalproof with cable protection

3D Angle Adjusting System

Screw with locking system

Open : $\alpha/2 \leq 30^\circ$

Close: $\alpha/2 \leq 10^\circ$

Tilt: $-20^\circ / +50^\circ$

Pan variable

Ultimate LED technology

New generation White Light LED
Surface mounting technology (SMT)

Long life

High efficiency and low consumption LED
LED MTBF: 50.000 hours

Main Power Supply Inside

Easy to install 100-240 VAC main power supply

Heat dispersion body

Die cast Aluminium radiant body for optimal thermal yield

Options

Available in versions with different LED angle beam : $15^\circ / 30^\circ / 60^\circ / 120^\circ$
Up to 280m

Technology

Aluminium die cast molding and Technopolymers
Weatherproof rate IP66 e IP67

Low Voltage

Whole range available also in 12-24 VAC/DC



HYPERION ONE WL

Compact White Light LED Illuminator

Long life

High efficiency and low consumption LED
LED MTBF: 50.000 hours

Wall/Housing Mount Bracket

Compatible with any camera housings

Available in versions with different LED angle beam : $15^\circ / 30^\circ / 60^\circ / 120^\circ$
Up to 200m

N.1 Cable Glands M16x1.5 precabled (2m)

Main Power Supply Inside

Easy to install 100-240 VAC main power supply

Low Voltage

Whole range available also in 12-24 VAC/DC

ACCESSORIES

BWHYP1 : Optional Wall Bracket

BWRHYP1 : Adapter for Linea R Camera Housing

CR2 : External Photocell switch with adjustable threshold 230Vac IP66



HYPERION WL / HYPERION ONE WL

Maximum distance beam charts

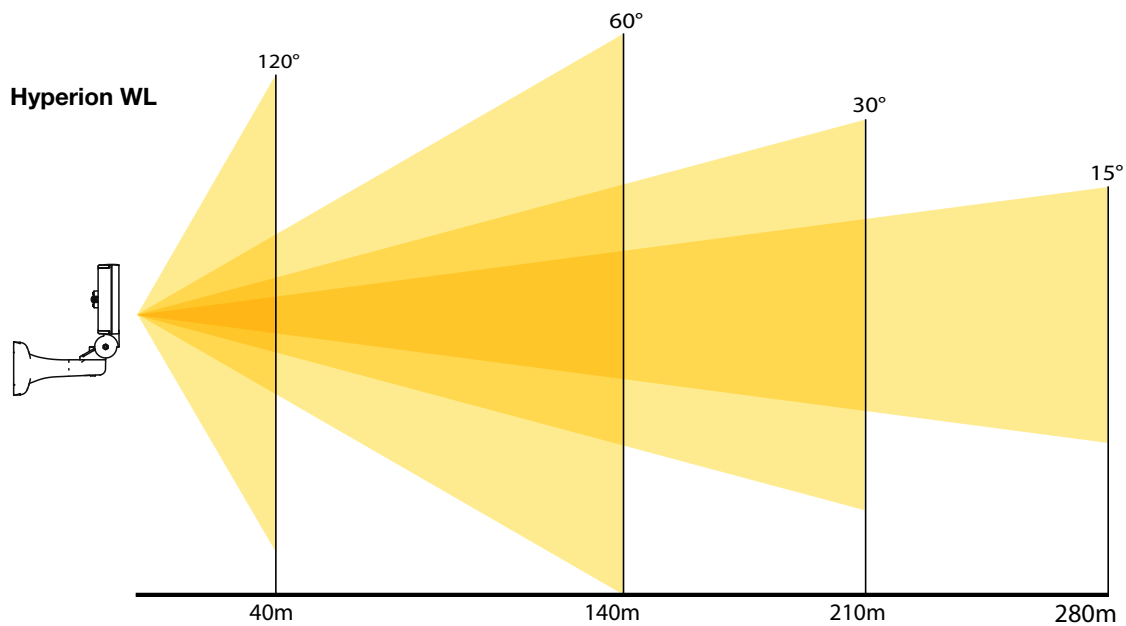

Hyperion One WL

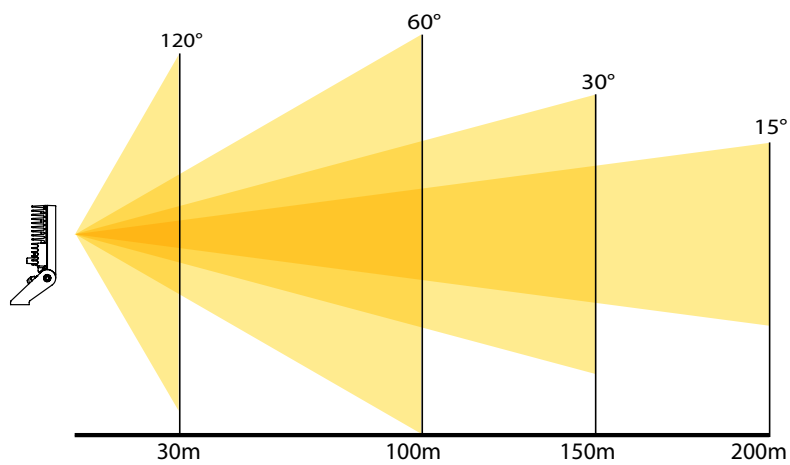

HYPERION ONE PoE

PoE Infrared LED Illuminator
compatible with any camera housings.

Wall/Housing Mount Bracket
Compatible with any camera housings

Ultimate LED technology
850nm new generation Infrared LED
940nm available on request
Surface mounting technology (SMT)

Long life
High efficiency and low consumption LED
LED MTBF: 50.000 hours

Power over Ethernet
Easy to install with integrated PoE splitter
(IEEE 802.3af compliant)

Heat dispersion body
Die cast Aluminium radiant body for optimal thermal yield

Options
Available in versions with different LED angle beam : 15° / 30° / 60° / 120°
Available in versions with different LED power
Up to 150m

Technology
Aluminium die cast molding
and Technopolymers
Weatherproof rating IP66 / IP67
Dry contact for Day/Night camera switch
Integrated photocell switch

Mechanical
N.2 Cable Glands M16x1.5 precabled (2m)
Sealed RJ45 Male and Female Connectors

ACCESSORIES
BWHYP1 : Optional Wall Bracket
BWRHYP1 : Adapter for Linea R Camera Housing

HYPERION HYBRID

Cable Management
Vandalproof with cable protection

3D Angle Adjusting System

Ultimate LED technology
850nm new generation Infrared LED
and new generation White Light LED

Main Power Supply Inside

Technology
Weatherproof rate IP66 / IP67
Dry contact for Day/Night camera switch



NANO IR

Infrared LED Illuminator

Wall/Housing Mount Bracket

Compatible with any camera housings

Ultimate LED technology

850nm new generation Infrared LED

940nm available on request

Surface mounting technology (SMT)

Long life

High efficiency and low consumption LED

LED MTBF: 50.000 hours

Main Power Supply Inside

Easy to install 240 VAC main power supply

Heat dispersion body

Die cast Aluminium radiant body for optimal thermal yield

Options

Available in versions with different LED angle beam : 15° / 30° / 60°/ 120°

Up to 40m

Technology

Aluminium die cast molding

and Technopolymers

Weatherproof rate IP66

Mechanical

N.1 Cable Glands M16x1.5 precabled (2m)



NANO WL

White Light LED Illuminator

Wall/Housing Mount Bracket

Compatible with any camera housings

Ultimate LED technology

New generation Infrared LED

Surface mounting technology (SMT)

Long life

High efficiency and low consumption LED

LED MTBF: 50.000 hours

Main Power Supply Inside

Easy to install 240VAC main power supply

Heat dispersion body

Die cast Aluminium radiant body for optimal thermal yield

Options

Available in versions with different LED angle beam : 15° / 30° / 60°/ 120°

Up to 60m

Technology

Aluminium die cast molding

and Technopolymers

Weatherproof rate IP66

Mechanical

N.1 Cable Glands M16x1.5 precabled (2m)



Housings **LINEA 1**

Camera housing available in two lengths, wall or ceiling mounting brackets, with cable management wall bracket or in vandal resistant version

Construction
Aluminium

Internal dimensions
WxH 70 x 70 mm

Working length
250 mm, 300 mm

Weatherproof rating
IP66

Cable glands
No. 2 M16x1,5

Opening
Slide and hang system

Colour
White RAL9002 or black RAL9005
with silver anodized sunshield

ACCESSORIES

12-24Vac/Vdc or 100-240Vac heater with thermostat

100-240Vac double and triple heater with thermostat

400mA power supply unit, 230Vac/12Vdc or 230Vac/24Vac

24Vac or 230Vac blower with thermostat (P version only)

Anti-condensation glass

Vandal-proof glass

Camera height adjustment kit



KIT1A



KIT1P



KIT1C



KIT1AC

Housings **LINEA 2**

Camera housing built in aluminium and thermoplastic resin, wall or ceiling mounting brackets, wall mount bracket with cable protection conduit and cable management wall bracket

Construction

Aluminium and thermoplastic resin

Internal dimensions

WxH 75 x 75 mm

Working length

270 mm

Weatherproof rating

IP66

Cable glands

No. 2 M16x1,5

Opening

Slide and hang system

Colour

White RAL9002

ACCESSORIES

12 Vac/Vdc, 24Vac/Vdc or 230Vac heater with thermostat

400mA power supply unit, 230Vac/12Vdc or 230Vac/24Vac

24Vac or 230Vac blower with thermostat (F and P versions only)

Camera height adjustment kit



KIT2A



KIT2P



KIT2F

KIT2AC



Housings **LINEA 3**

Large capacity and side opening camera housing, suitable for big lenses, standard or vandal resistant versions, with wall bracket



Construction
Aluminium

Internal dimensions
WxH 140 x 100 mm

Working length
400 mm

Weatherproof rating
IP65

Cable glands
No. 3 M16x1,5

Opening
Side opening

Colour
White RAL9002

ACCESSORIES

12-24Vac/Vdc or 100-240Vac heater with thermostat

400mA power supply unit, 230Vac/12Vdc or 230Vac/24Vac

230Vac blower with thermostat

Anti-condensation glass

Vandal-proof glass

Adapter for brackets different from the BW3H3

Camera height adjustment kit



Housings **LINEA 6**

Camera housing available in three lengths, wall or ceiling mounting brackets, with cable management bracket for wall or ceiling applications and in vandal resistant version.

Available standard or IP version with sealed RJ45 connector, developed for digital cameras

Construction

Aluminium

Internal dimensions

WxH 105 x 86 mm

Working length

250 mm, 300 mm, 350 mm

Weatherproof rating

IP66

Cable glands

No. 3 M16x1,5

Opening

Slide and hang system

Colour

White RAL9002 or silver anodized
with black RAL9005 front and back covers

ACCESSORIES

12-24Vac/Vdc or 100-240Vac heater
with thermostat

100-240 Vac double and triple heater with
thermostat

400mA power supply unit, 230Vac/12Vdc or
230Vac/24Vac

100-240 Vac/12Vdc, 2,1A
Wide Range Power supply unit

24Vac or 230Vac blower with thermostat

Anti-condensation glass

Vandal-proof glass

Tamper Switch

Sealed RJ45 male connector
(for IP version)

Camera height adjustment kit



KIT6P



KIT6C



KIT6AC



Housings **LINEA R**

Camera housing with flip-top opening system, available in two lengths, wall or ceiling mounting brackets, with cable management wall bracket and in vandal resistant version



KITRA

Construction
Aluminium

Internal dimensions
WxH 75 x 75 mm

Working length
230 mm, 270 mm

Weatherproof rating
IP66

Cable glands
No. 4 M16x1,5

Opening
Flip top

Colour
White RAL9002

ACCESSORIES

12-24Vac/Vdc or 100-240Vac
heater with thermostat

400mA power supply unit,
230Vac/12Vdc or 230Vac/24Vac

24Vac or 230Vac blower with thermostat

Vandal-proof glass



KITRP



KITRAC



Housings **LINEA 11**

Weatherproof camera housing made of extruded Aluminium and ABS, with integrated sunshield, wall bracket or ceiling mount. Available standard or IP version with sealed RJ45 connector developed for digital cameras

Construction

Aluminium and ABS

Internal dimensions

BxH 85 x 75 mm

Working length

300 mm

Weatherproof rating

IP66

Cable Glands

N. 2 M16x1,5 (KIT11A standard)

or

N. 1 M16x1,5 and N. 1 sealed RJ45 connector (KIT11A IP)

Opening

Slide and hang system

Colour

White RAL9002

ACCESSORIES

12-24Vac/Vdc or 100-240Vac
Heater with thermostat

400mA, 230Vac/12Vdc or
230Vac/24Vac
Power supply unit

100-240 Vac/12Vdc, 2,1A
Wide Range Power supply unit

2Vdc or 24Vac or 230Vac
Blower with thermostat

Male Sealed RJ45 Connector
(for IP version)

Camera height adjustment kit



KIT11A



KIT11A IP

KIT11AC

Housings **HiPoE MKII** and **HiPoE MKII Plus**

LINEA 11A IP

LINEA 6A IP

LINEA 6P

LINEA RP



LINEA RP

High Power over Ethernet Camera Housing, 24W Hi-PoE Gigabit capable dedicated splitter (IEEE 802.3at compliant), Weatherproof with Sealed RJ45 Connector, Heater with thermostat, Blower kit with thermostat.

Dual Fast IP Connections

A new designed HiPoE board has been developed by Tekno System.

All the new HiPoE MKII camera housings are equipped with both RJ45 and Punch Down Terminal fast connection systems offering the installer a choice of the most suitable solution.

Plug & Play

The pre-assembled internal CAT5e with the RJ45 male plug termination makes this a real Plug & Play solution.

The Dual Fast IP Connections HiPoE camera housings have been engineered with built-in flexibility to host and allow any kind of digital camera, with or without PoE options, to work seamlessly in a HiPoE CCTV system.



LINEA 6A



LINEA 11A



HiPoE MKII

If you want to supply an IP (but not PoE) camera you have to use the HiPoE MKII version; in this case you must use the two terminal blocks (output selectable +12VDC or 14.5VDC) and two wires from the splitter to the camera for the power supply and a separate CAT5e cable for the data.

HiPoE MKII Plus

If you want to supply directly a PoE camera (IEEE 802.3af compliant) with just one CAT5e cable from the splitter you have to use the HiPoE MKII Plus version, which has a built in PoE injector, IEEE 802.3af compliant.

Splitter compatible with:

- Microsemi/PowerDsine HiPoE Multi Port Midspan (8 port version)
- Pihong High Power Gigabit PoE Midspan series

ACCESSORIES

- Field attachable connector RJ45
- HiPoE Injector/Midspan
- Blower with thermostat
- Heater with thermostat
- Vandal-proof glass (for Linea 6, Linea R)
- Camera height adjustment kit



KIT 11A IP



KIT 6A IP

the solution for IP CAMERAS is HiPoE MKII

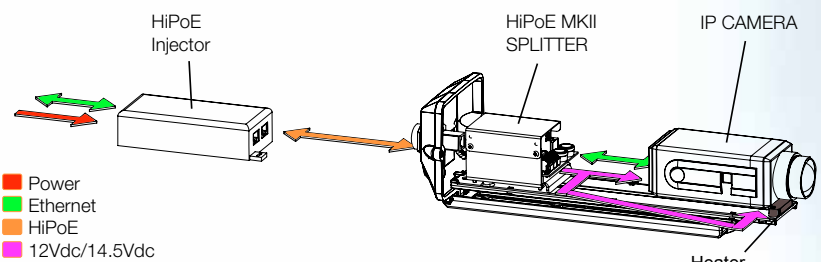

the solution for IP PoE CAMERAS is HiPoE MKII Plus

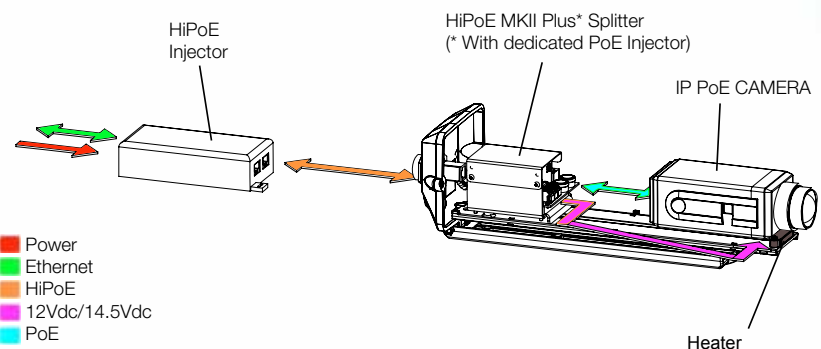

Thermal Camera Housings

**Wide range of solutions for thermal cameras:
 housings with Germanium window for professional
 and industrial applications**

Germanium filter factory installed
 available for Linea 1, Linea 6, Linea R,
 Linea X, CHXES, CHEP camera housings

AR Coating (anti-reflection) on both sides

Hard Carbon Coating (anti-scratching) on external side

Weatherproof IP66

Ø 50mm useful window

High Performance Housing

Camera housing for wide applications, being
 vandal resistant, high waterproof rated and
 having top quality components mounted.

IP68 at 1,5 m

IK10

Length 300mm

No. 3 M16x1,5 Metallic cable glands

8mm polycarbonate window

(with anti-crashing and anti-scratching coating)

Versions: Wall Mount (KIT6A-HP), Ceiling Mount (KIT6AC-HP)

ACCESSORIES

12-24Vac/Vdc or 100-240Vac heater with thermostat

400mA power supply unit, 230Vac/12Vdc or 230Vac/24Vac

100-240 Vac/12Vdc, 2,1A Wide Range Power supply unit

Pressurized Housing

Sealed and pressurized outdoor camera housing designed to protect the camera and lens in harsh environmental conditions. The pressurized camera housing increases the camera's reliability and greatly reduces the cost of maintenance.

Construction

Aluminium

Internal dimensions

W x H 105 x 86 mm

Usable length

300 mm

Weatherproof rating

IP68 at 3m depth

Window

IK10 thick polycarbonate

Cable glands

No. 3 M16x1,5 Metallic

Opening

Slide and hang system

Colour

White RAL9002

Pressurized

Easy to pressurize in the field with dry nitrogen to prevent impurities from contaminating the camera and lens components or moisture.

Pressure relief valve

Prevents over-charging of the camera housing.

Built-in Manometer

Allows the installer to choose the right pressure and keep it under control.

Application

For industrial environments where dust or powder is present. Also it is ideally suited for very hot environments where fan cooling is not a viable option due to sand storms

Temperature range

-20°/+60°C



Signal plates

16x16 or 32x32 cm warning plates for CCTV controlled areas



Accessories for camera housings

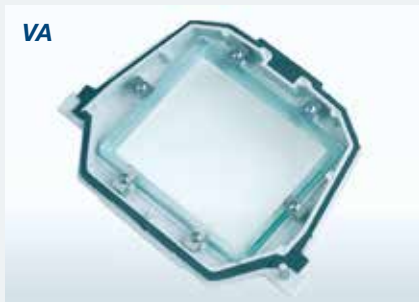

Compatibility chart

	Linea 1	Linea 2	Linea 3	Linea 6	Linea R	Linea 11
VC - Anti-condensation glass	•	-	•	•	-	-
VA - Vandal-proof glass	•	-	•	•	•	-
HT - Heater	•	•	•	•	•	•
HTT/HTTT - Double or triple heater	•	-	-	•	-	-
AL - Power supply unit	• (3)	•	•	• (3)	•	•
ALWR - Wide range power supply unit 100-240Vac/12Vdc 2,1A	-	-	•	•	-	• (3)
V - Blower	• (5)	• (1)	•	• (4)	•	• (2)

(1) Available only on F and P versions. (2) Not to install with the power supply. (3) Not to install with the Blower
 (4) Available with ALWR only on P version. (5) Available only on P version

Camera brackets



Wall bracket, 110 mm, 140 mm or 190 mm lengths



Wall bracket with cable management, 160 mm length



Telescopic wall bracket, 210÷305 mm length



Wall bracket, 185 mm length



Ceiling bracket, 190 mm length



Telescopic ceiling bracket, 210÷300 mm length



Wall bracket, 185 mm length

Adapters for camera housing brackets



PA1 Pole mount adapter for one wall bracket



PA2 Pole mount adapter for two wall brackets



CM Corner mount adapter for wall bracket

Horizontal pole adapter (accessory for PA1, PA2)



Brackets for housings



BW9H6 Wall mount bracket, 164 mm length



BW2H2 Wall mount bracket, 233 mm length



BW6H6 Wall mount bracket, 265 mm length



CBRH6 Ceiling mount bracket, 450 mm length



BW1H1 Wall mount bracket, 218 mm length



BW9H6 + PAWC Pole mount bracket with stripes

Compatibility chart

	Housings CH1A	Housings CH2A	Housings CH3	Housings CH6A	Housings CHRA	Housings CH11
BW9H6	•	•	-	•	•	•
BW2H2	•	•	-	•	-	-
BW6H6	•	•	-	•	•	-
CBRH6	•	•	-	•	•	•
BW1H1	•	•	-	•	•	•
BW9H6 + PAWC	•	•	-	•	•	•



Tekno System S.p.A.

Via Rostoncello, 1
36010 Carrè (VI) Italy
Phone: +39 0445 314324
Fax: +39 0445 314319
info@teknoystem.eu
www.teknoystem.eu



tekno system®

Italian design for CCTV since 1979

Technical data and product features might be modified without any warning.

M 12/12 1600 EN